

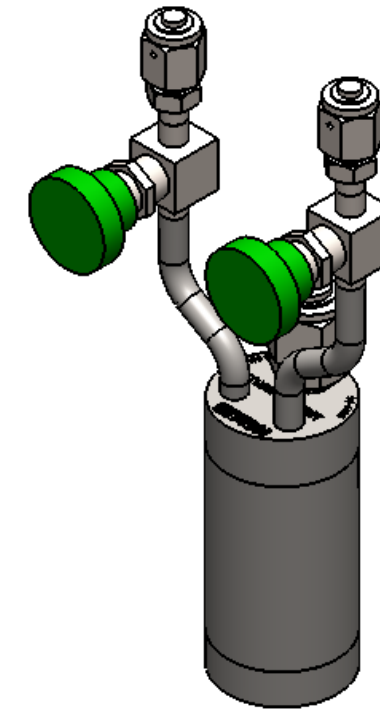

STAINLESS STEEL BUBBLER, 150ml, VERTICAL, ELECTROPOLISHED WITH FILL-PORT, HIGH TEMP VALVES (315°C) WITH ROTATED HANDLES, DOT 4B, UN STAMPED

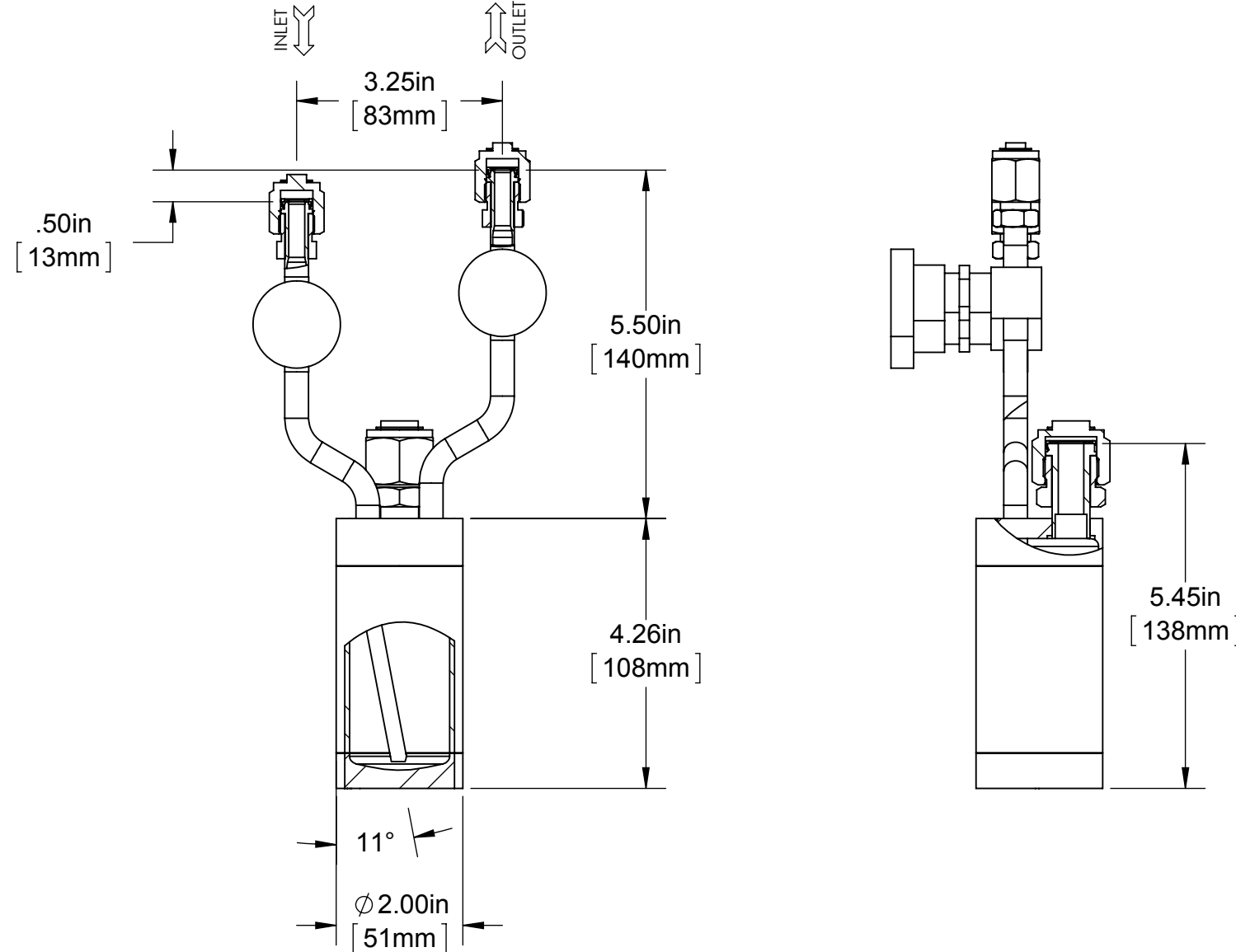
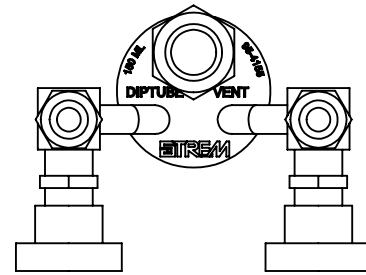

DESIGN SPECIFICATION	
CYLINDER MODEL	95-4155
CYLINDER SIZE	2" DIAMETER
CYLINDER WORKING VOLUME	150ml
CYLINDER TOTAL VOLUME	166ml
CYLINDER TARE WEIGHT	2.59 lbs
DESIGN PRESSURE	260 psi
TEST PRESSURE	520 psi
DESIGN TEMPERATURE	600F/315C
INTERNAL FINISH	10ra, MIRROR, ELECTROPOLISH
EXTERNAL FINISH	10ra, MIRROR, ELECTROPOLISH
FILLPORT	SWAGELOK, 1/2 VCR
INLET VALVE	SWAGELOK, SS-4H-TW
OUTLET VALVE	SWAGELOK, SS-4H-TW
THERMOWELL	NO
DIPTUBE	YES
MATERIAL OF CONSTRUCTION	316L SS
D.O.T. SPECIFICATION	4B-260
TOLERANCE (UNLESS OTHERWISE SPECIFIED)	±.060

**NOTICE OF CONFIDENTIAL INFORMATION**

INFORMATION CONTAINED HEREIN IS CONFIDENTIAL AND IS THE PROPERTY OF STREM CHEMICALS, INCORPORATED. IT SHALL NOT BE REPRODUCED, DISCLOSED IN FULL OR IN PART OR PASSED ON TO THIRD PARTIES WITHOUT THE WRITTEN CONSENT OF STREM CHEMICALS, INC. NO EQUIPMENT, MACHINERY OR PARTS TO WHICH THE DRAWING RELATES TO MAY BE MANUFACTURED BY A THIRD PARTY WITHOUT THE WRITTEN CONSENT FROM AN AUTHORIZED REPRESENTATIVE OF STREM CHEMICALS, INC.