

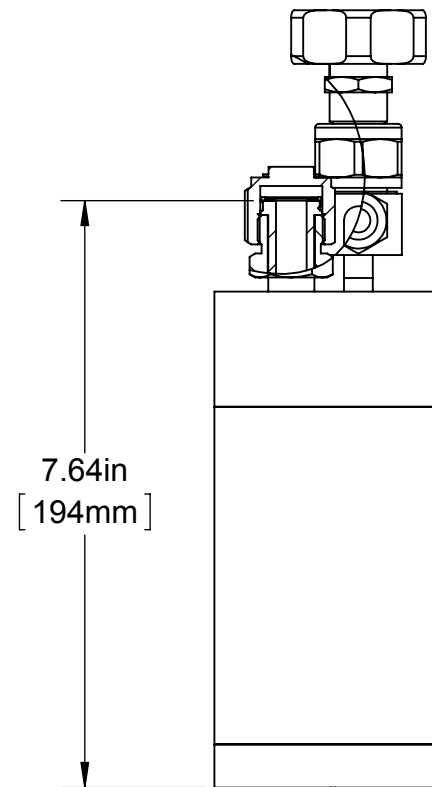

TECHNICAL NOTES: STREM ITEM NUMBER 95-5599

|      |            |
|------|------------|
| REV. | DATE       |
| 02   | 03/31/2015 |

STAINLESS STEEL BUBBLER, 600ml, HORIZONTAL IN LINE, ELECTROPOLISHED WITH FILL-PORT, PCTFE VALVE STEM TIP, DOT 4B, UN STAMPED

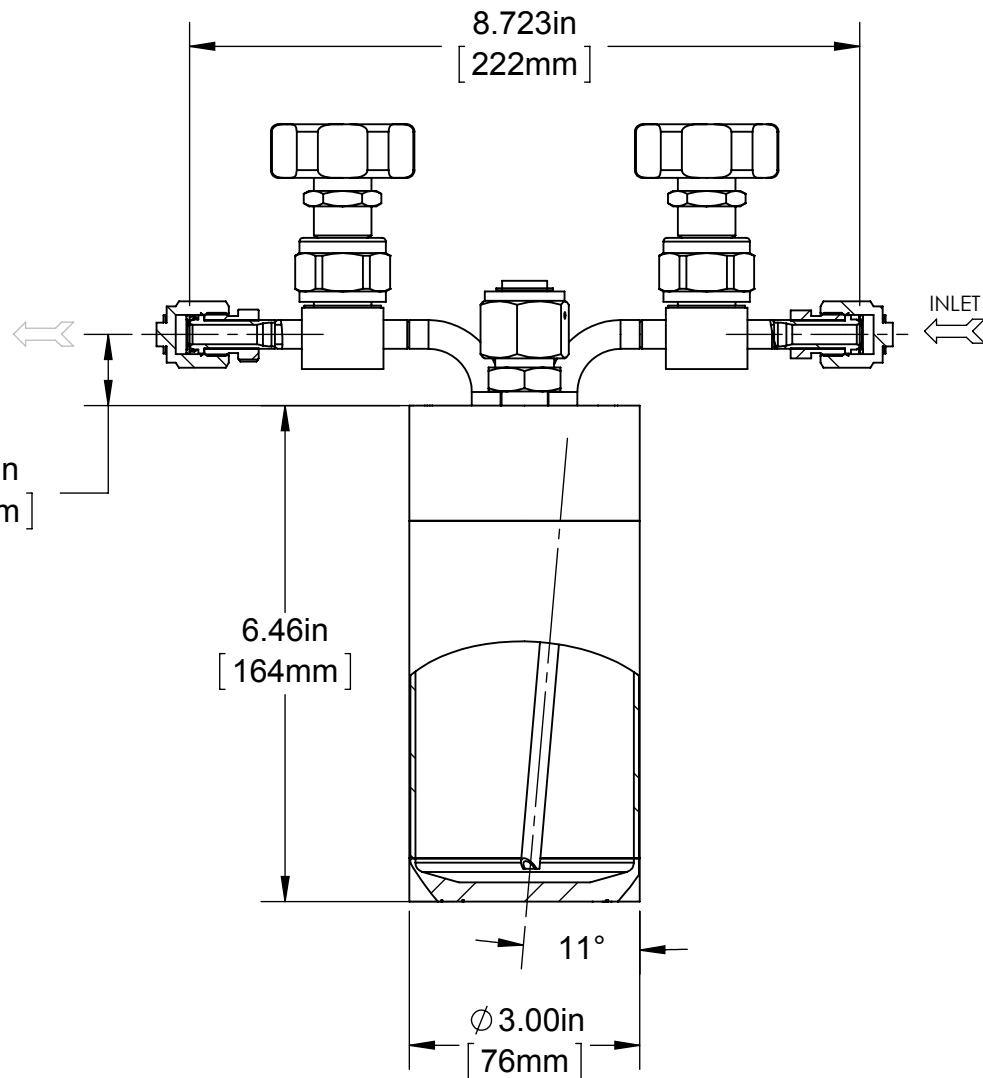
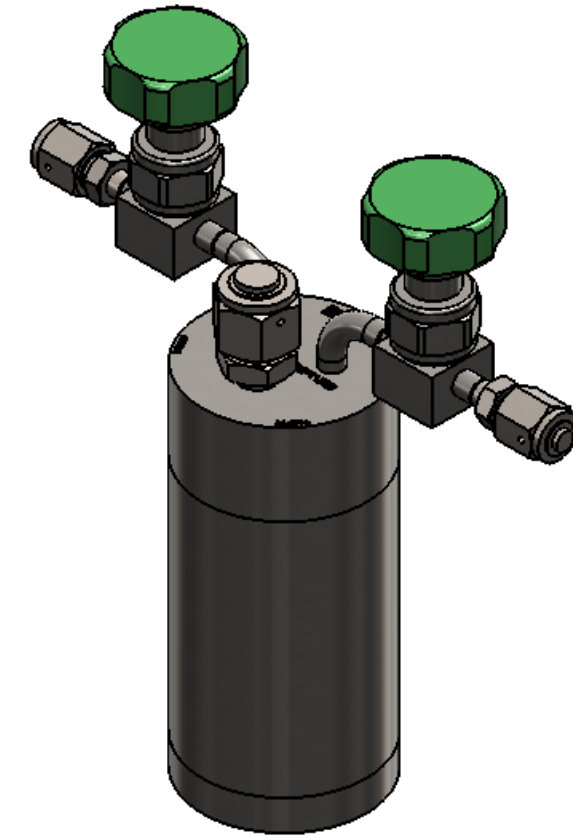
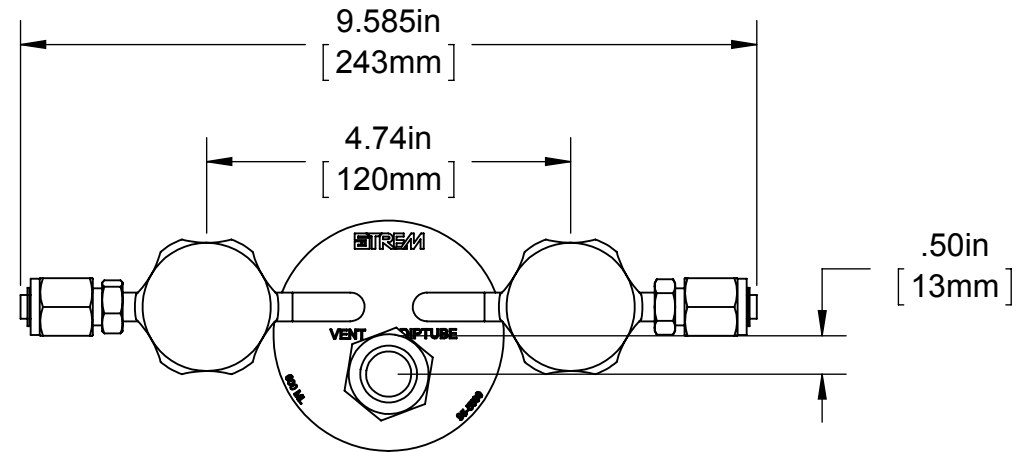

| DESIGN SPECIFICATION                   |                             |
|--|-----------------------------|
| CYLINDER MODEL                         | 95-5599                     |
| CYLINDER SIZE                          | 3" DIAMETER                 |
| CYLINDER WORKING VOLUME                | 600ml                       |
| CYLINDER TOTAL VOLUME                  | 620ml                       |
| CYLINDER TARE WEIGHT                   | 5.18 lbs                    |
| DESIGN PRESSURE                        | 260 psi                     |
| TEST PRESSURE                          | 520 psi                     |
| DESIGN TEMPERATURE                     | 250F/121C                   |
| INTERNAL FINISH                        | 10ra, MIRROR, ELECTROPOLISH |
| EXTERNAL FINISH                        | 10ra, MIRROR, ELECTROPOLISH |
| FILLPORT                               | SWAGELOK, 1/2 VCR           |
| INLET VALVE                            | SWAGELOK, SS-DSTW-4         |
| OUTLET VALVE                           | SWAGELOK, SS-DSTW-4         |
| THERMOWELL                             | NO                          |
| DIPTUBE                                | YES                         |
| MATERIAL OF CONSTRUCTION               | 316L SS                     |
| D.O.T. SPECIFICATION                   | 4B-260                      |
| TOLERANCE (UNLESS OTHERWISE SPECIFIED) | ±.060                       |

**NOTICE OF CONFIDENTIAL INFORMATION**

©COPYRIGHT 2014 STREM CHEMICALS, INC. ALL RIGHTS RESERVED.

THIS IMAGE IS PROTECTED UNDER FEDERAL AND INTERNATIONAL COPYRIGHT LAW. NO PART OF THIS IMAGE MAY BE REPRODUCED, STORED OR TRANSMITTED IN ANY FORM BY ANY MEANS WITHOUT THE PRIOR WRITTEN CONSENT OF STREM CHEMICALS, INC. THIS IMAGE IS PROVIDED SOLELY AS A DEPICTION OF THE ITEM DESCRIBED. THERE IS NO RIGHT OR LICENSE GRANTED HEREIN TO CONSTRUCT THE ITEM DEPICTED IN THE IMAGE OR TO CREATE DERIVATIVE WORKS OF THE SAME WITHOUT THE PRIOR WRITTEN CONSENT OF STREM CHEMICALS, INC. ALL SUCH RIGHTS ARE EXPRESSLY RESERVED.