

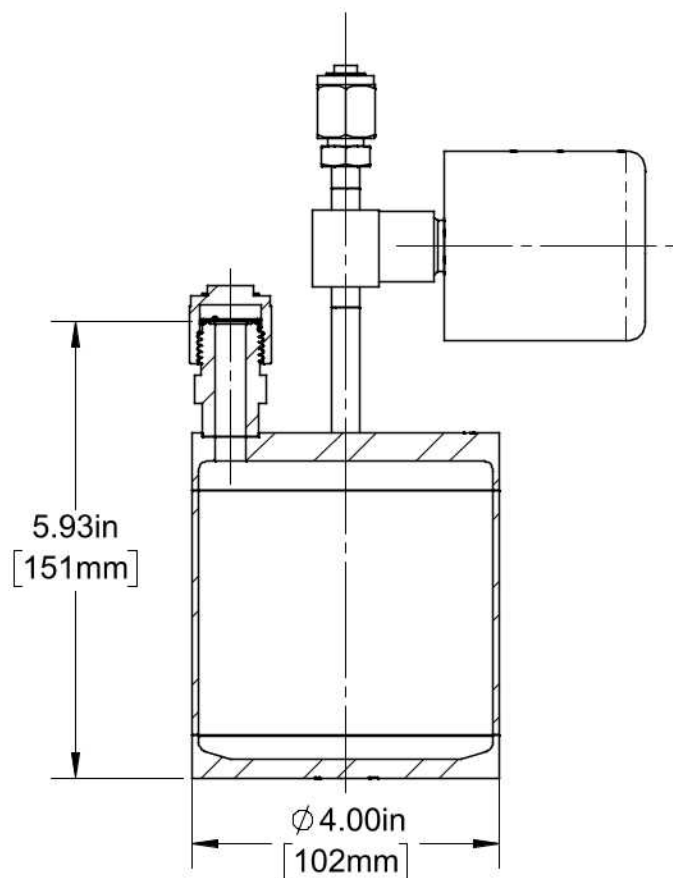

REV.	DATE
01	12/04/2020

STAINLESS STEEL BUBBLER, 600ML, VERTICAL, ELECTROPOLISHED WITH FILL-PORT, TEMP VALVES (120°C) PNUMATIC, DOT 4B, UN STAMPED

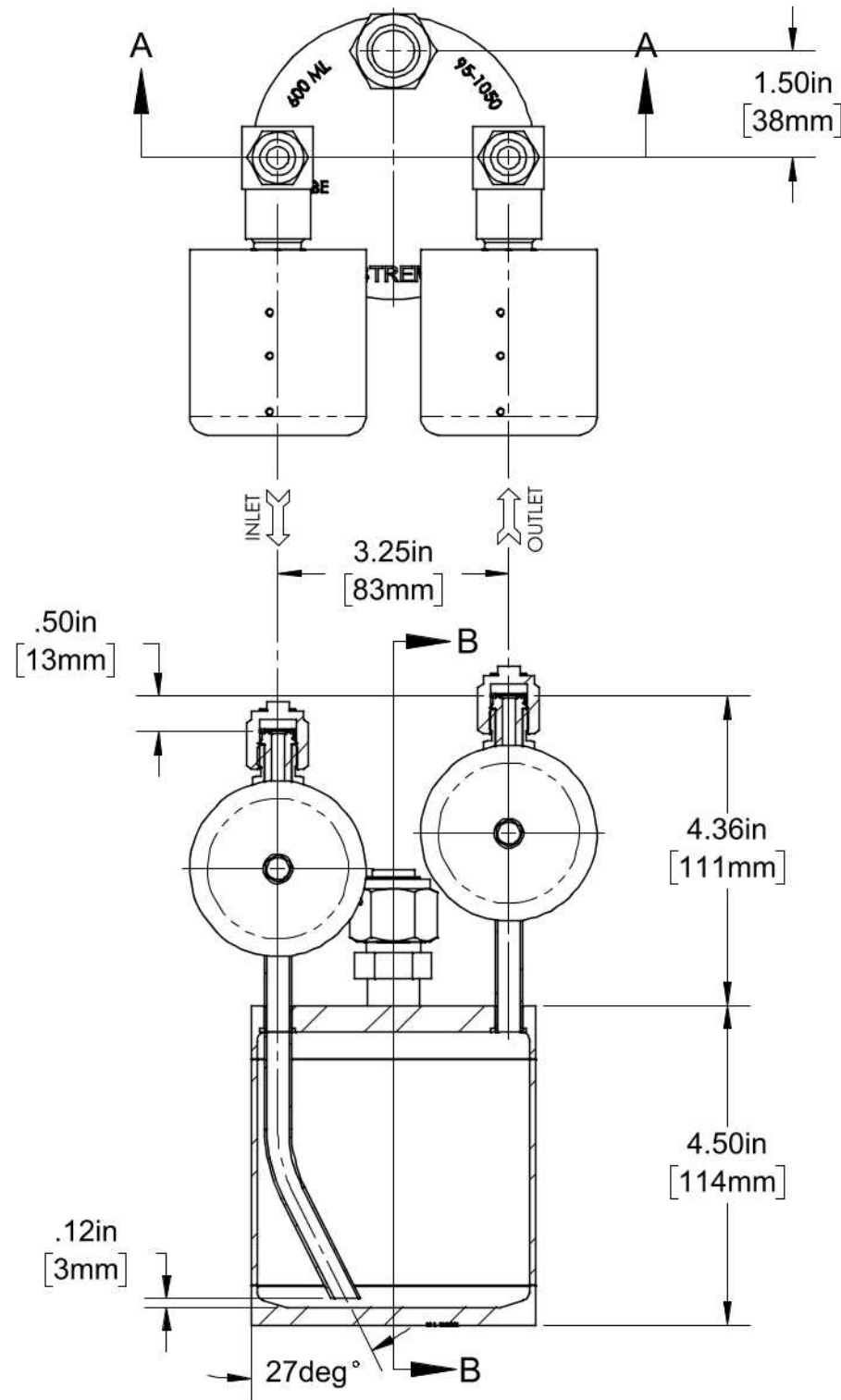
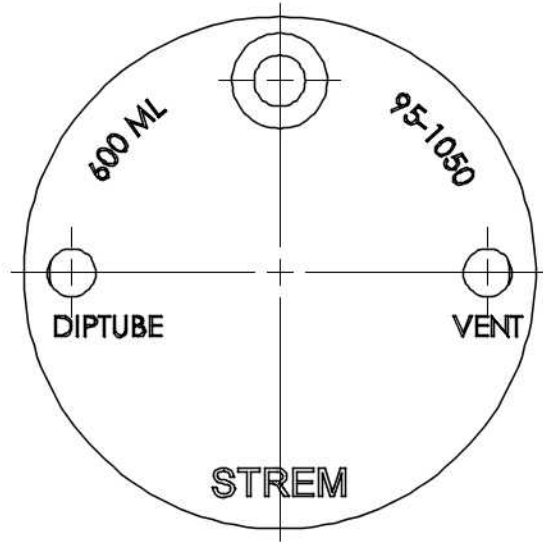

DESIGN SPECIFICATION	
CYLINDER MODEL	0603-02 STREM 95-1050
CYLINDER SIZE	4" DIAMETER
CYLINDER WORKING VOLUME	600CC
CYLINDER TOTAL VOLUME	650CC
CYLINDER TARE WEIGHT	5.1 LBS / 2.3kg
DESIGN PRESSURE	150 PSI
TEST PRESSURE	300 PSI
DESIGN TEMPERATURE	250F/120C
INTERNAL FINISH	10ra, ELECTROPOLISH
EXTERNAL FINISH	10ra, ELECTROPOLISH
FILLPORT	1/2" MVCR
INLET VALVE	GASFLO DIAPH - AIR, Vespel
OUTLET VALVE	GASFLO DIAPH - AIR, Vespel
THERMOWELL	NO
DIPTUBE	YES
MATERIAL OF CONSTRUCTION	316L SS
D.O.T. SPECIFICATION	DOT4B-150
TOLERANCE (UNLESS OTHERWISE SPECIFIED)	±.020

NOTICE OF CONFIDENTIAL INFORMATION
 INFORMATION CONTAINED HEREIN IS CONFIDENTIAL AND IS THE PROPERTY OF STREM CHEMICALS, INCORPORATED. IT SHALL NOT BE REPRODUCED, DISCLOSED IN FULL OR IN PART OR PASSED ON TO THIRD PARTIES WITHOUT THE WRITTEN CONSENT OF STREM CHEMICALS, INC. NO EQUIPMENT, MACHINERY OR PARTS TO WHICH THE DRAWING RELATES TO MAY BE MANUFACTURED BY A THIRD PARTY WITHOUT THE WRITTEN CONSENT FROM AN AUTHORIZED REPRESENTATIVE OF STREM CHEMICALS, INC.